

1 Omkring de letter bij de ontwikkeling(en) waarmee je een kubus kunt maken.

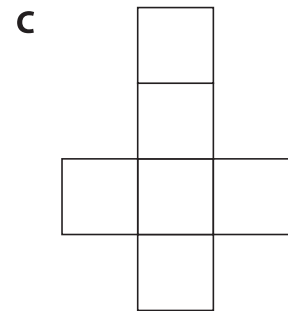

2 Doorstreep de letter bij de ontwikkeling(en) waarmee je geen balk kunt maken.

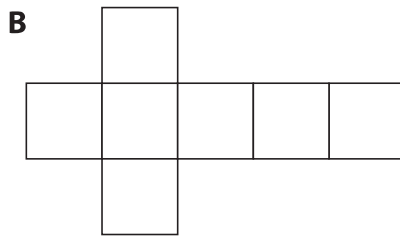
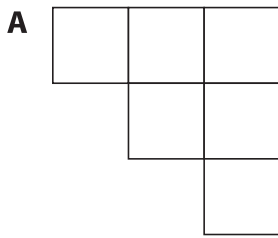
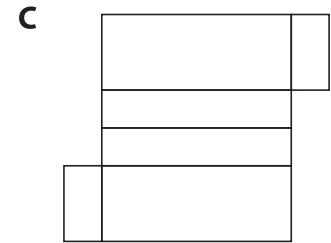
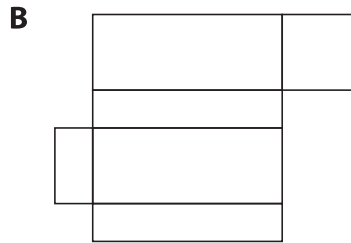
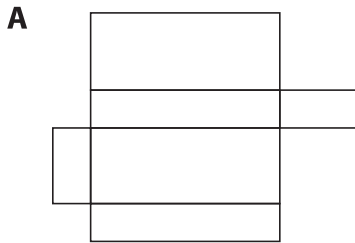

3 Geef de lichamen en hun ontwikkeling dezelfde kleur.

Teken de ribben in de ontwikkelingen.

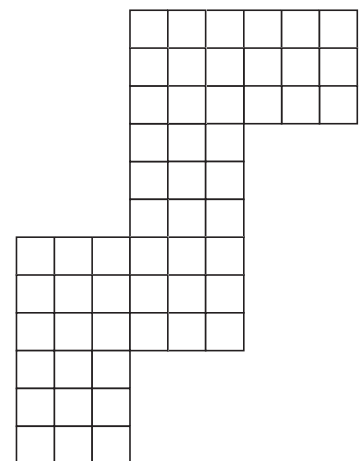
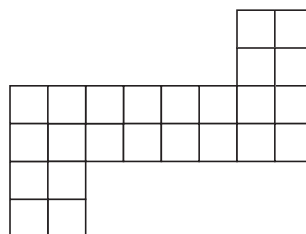
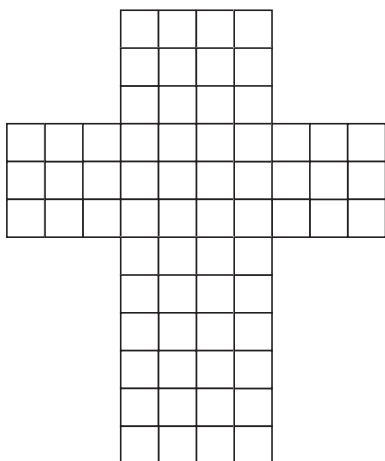
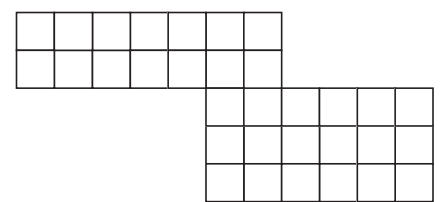
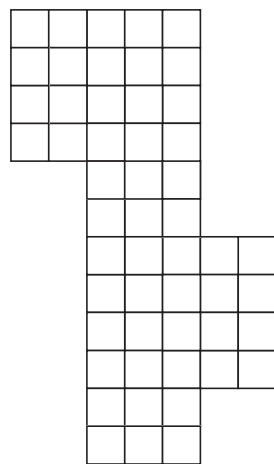
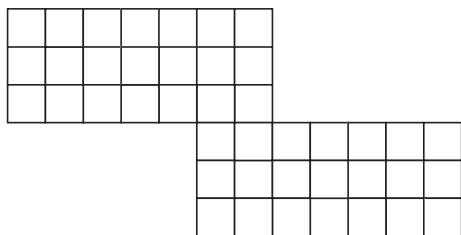
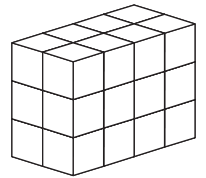
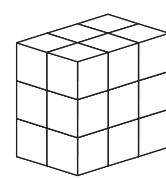
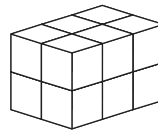
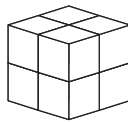
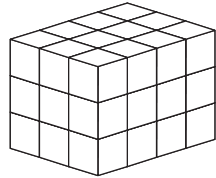
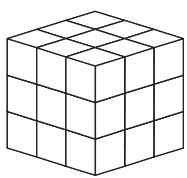

**4** Doorstreep de letter bij de ontwikkelingen waarmee je geen cilinder kunt maken.



A

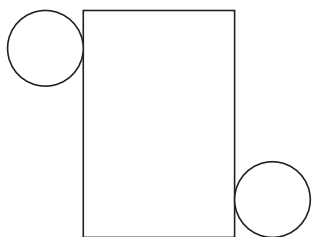

B

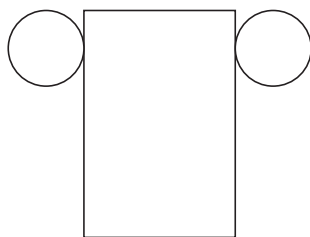

C



D

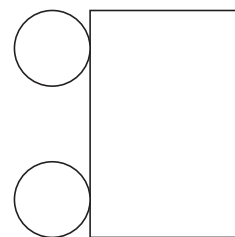

**5** Welke ontvouwing hoort bij welke ruimtefiguur?



a en .....

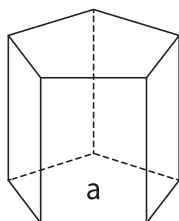

b en .....

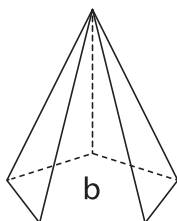

c en .....

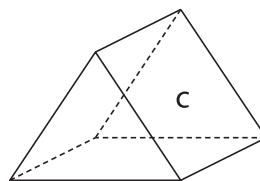

d en .....

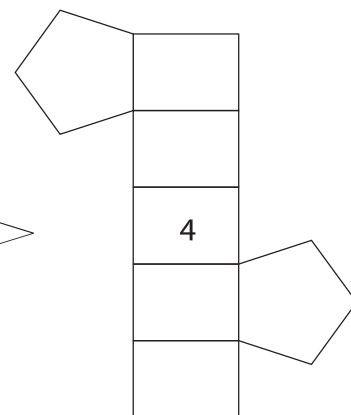
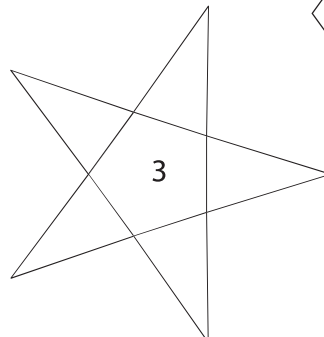
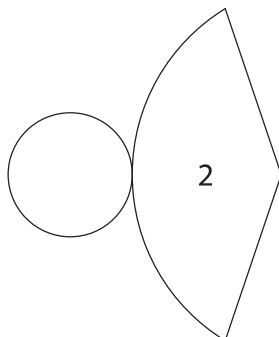
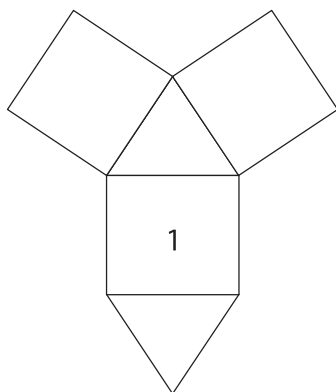
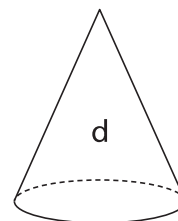

**6** Vul de ontwikkelingen aan zodat je er een kubus mee kunt maken.

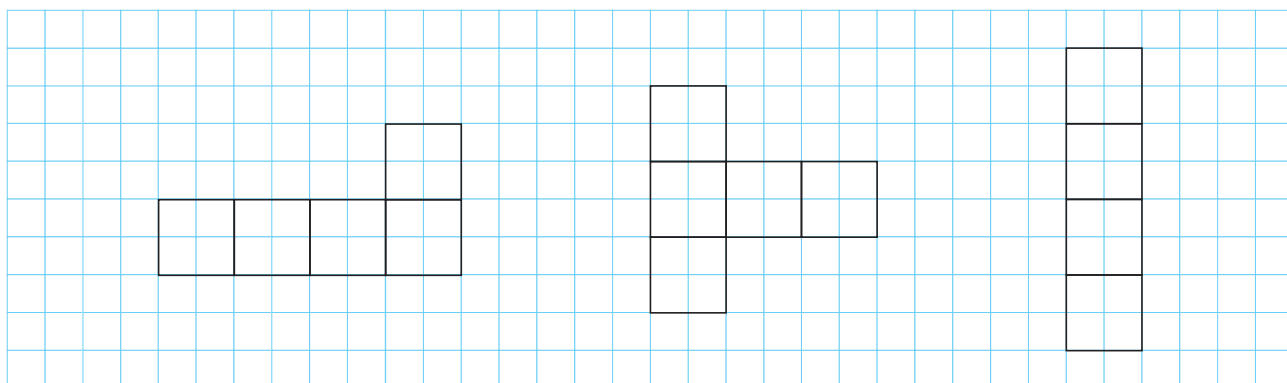

**7** De ontwikkeling van deze lichamen is niet volledig. Teken bij wat ontbreekt.

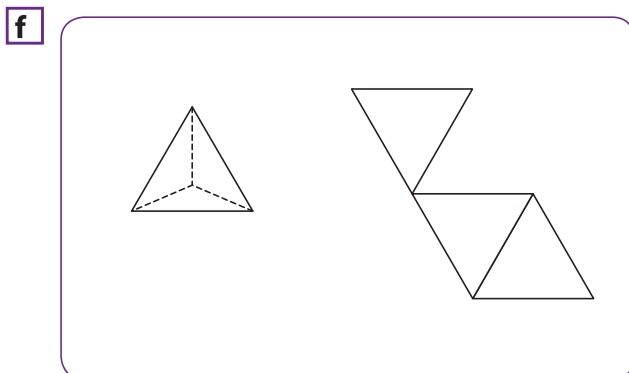
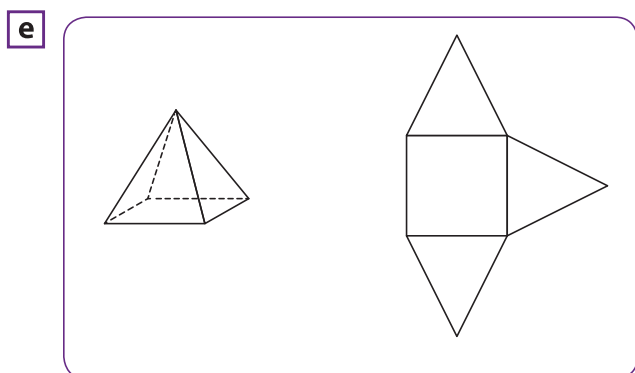
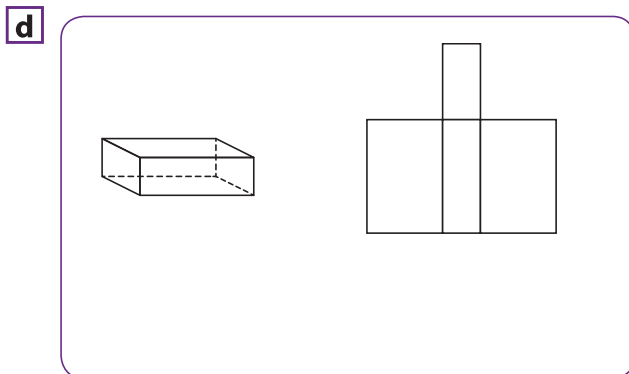
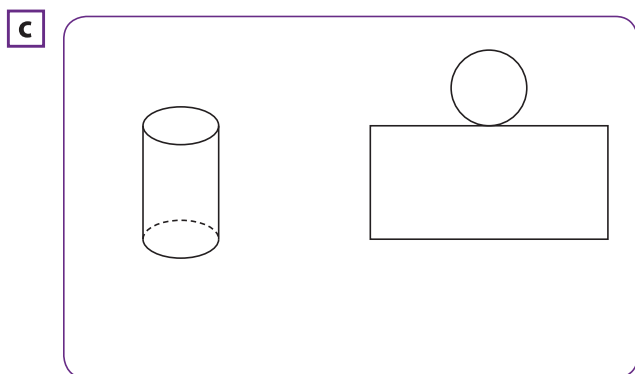
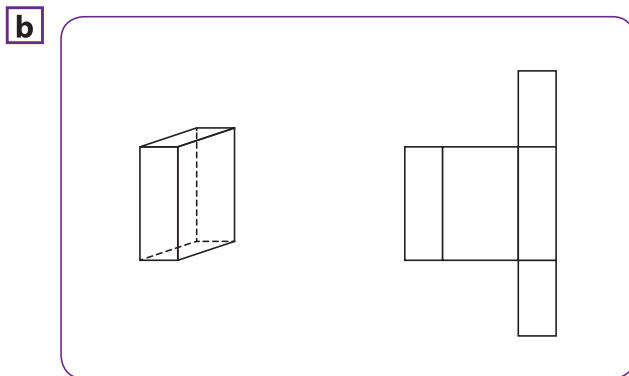
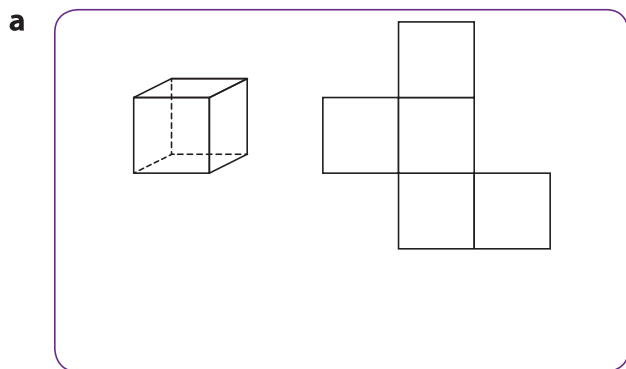

**8** Geef de zijvlakken op de ontwikkelingen de juiste kleur.

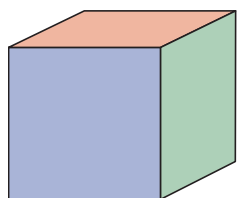

De overstaande zijvlakken van deze kubus hebben dezelfde kleur. Kleur de ontwikkelingen.

